

Chapter 19. Trail Camps	19-1
19.1. Types of Trail Camps	19-1
19.1.1. Public Trail Camps.....	19-1
19.1.1.1. Basic Trail Camps	19-1
19.1.1.2. Trailside Shelters.....	19-1
19.1.1.3. Equestrian Camps.....	19-1
19.1.2. Administrative Spike Camps	19-1
19.1.2.1. Backcountry Spike Camp	19-2
19.1.2.2. Frontcountry Spike Camp.....	19-2
19.2. Public Trail Camps.....	19-2
19.2.1. Site Selection.....	19-2
19.2.2. Site Design	19-4
19.2.3. Accessibility	19-4
19.2.4. Signage.....	19-4
19.2.5. Latrines	19-4
19.2.5.1. Pit Toilets.....	19-5
19.2.5.2. Self-Composting Toilets	19-5
19.3. Public Trailside Shelters.....	19-6
19.3.1. Site Selection.....	19-6
19.3.2. Structure and Site Design	19-6
19.4. Equestrian Camps.....	19-7
19.4.1. Site Selection.....	19-7
19.4.2. Hitching Rails.....	19-7
19.4.3. Corrals	19-8
19.4.3.1. Post and Rail Corral	19-11
19.4.3.2. Split Rail Corral	19-11
19.4.4. Water Troughs	19-15
19.4.5. Feed.....	19-15
19.5. Administrative Spike Camps.....	19-15
19.5.1. Site Selection.....	19-17
19.5.2. Site Design	19-18
19.5.3. Water	19-20
19.5.4. Kitchen.....	19-21
19.5.5. Showers.....	19-21
19.5.6. Latrine.....	19-21
19.6. Spike Camp Operations.....	19-22
19.6.1. Bears	19-22
19.6.2. Garbage.....	19-22
19.6.3. Meals	19-22

19.6.3.1. Small Crews	19-23
19.6.3.2. Large Crews	19-23
19.6.4. Sanitation Protocols	19-24
19.6.5. Kitchen	19-25
19.6.5.1. Hand Washing Station	19-25
19.6.5.2. Lunch	19-25
19.6.5.3. Breakfast and Dinner	19-25
19.6.5.4. Dish Washing Station	19-26
19.6.6. Common Areas	19-26
19.6.7. Latrine	19-26
19.6.8. Showers	19-27
19.6.9. De-Mobilizing Camp	19-27
19.7. Crew Behavior	19-28
19.7.1. Quiet Hours	19-28
19.7.2. Smoking	19-28
19.7.3. Alcohol	19-28

Figures

Figure 19.1 - Hitching Rail Placement	19-9
Figure 19.2 - Hitching Rail Construction	19-10
Figure 19.3 - Post and Rail Corral with Gate	19-12
Figure 19.4 - Split Rail Corral Construction	19-13
Figure 19.5 - Split Rail Gate	19-14
Figure 19.6 - Spike Camp Location	19-19

Photos

Photo 19.1 - Hitching Rail	19-8
Photo 19.2 - Administrative Spike Camp	19-17
Photo 19.3 - Fire Pit with Jungle Can	19-20
Photo 19.4 - Grey Water Sump	19-21
Photo 19.5 - Kitchen	19-25
Photo 19.6 - Dish Washing Station	19-27

Chapter 19. Trail Camps

With the exception of frontcounty administrative spike camps, trail camps are camps that are typically only accessible by foot, horse, boat, or bicycle. Trail camps include visitor camps, trailside shelters, equestrian camps, and administrative spike camps designed to accommodate overnight use on a trail. Below are the guidelines for design, construction, maintenance, and operation of such facilities. The planning and development of trail camps require all of the environmental review and permitting processes necessary for a trail project. See Chapter 3, *Planning and Environmental Compliance*, for further information.

19.1. Types of Trail Camps

19.1.1. Public Trail Camps

The purpose of a public trail camp is to provide a facility for overnight use by the public in a primitive park setting. Trail camps are placed to compliment the best use of the trail system, enhance the visitor experience, and minimize the impact of camping on the area. They are constructed in parks that are large enough to meet the need or desire for such facilities and can accommodate them without significant resource damage.

19.1.1.1. Basic Trail Camps

A basic trail camp provides the minimal facilities necessary to accommodate overnight camping along a trail or at a destination such as a lake. They usually consist of level tent pads with a fire ring.

19.1.1.2. Trailside Shelters

A trailside shelter is a more developed type of trail camp that provides overnight accommodation along a trail requiring multiple days to traverse, such as the California Coastal and Pacific Crest trails. A trailside shelter provides hikers with protection from the elements and promotes year-round trail usage. A trailside shelter is typically shared by multiple groups or individuals and is normally only available on a first come first served basis.

19.1.1.3. Equestrian Camps

An equestrian trail camp is designed to meet the needs of horses and their riders and, therefore, requires a larger site and additional amenities, such as hitching posts, corrals, and feeding and watering troughs.

19.1.2. Administrative Spike Camps

An administrative spike camp is an overnight facility designed to accommodate a trail crew while performing trail maintenance and construction. Spike camps may be

necessary when the project's commute time is so long that driving and hiking to and from the project site on a daily basis is impractical. A lengthy commute can elongate the project time line, increase costs, and adversely affect crew development and momentum. A spike camp provides a nearby location for a trail crew to eat, sleep, and meet personal hygiene needs.

19.1.2.1. Backcountry Spike Camp

A backcountry spike camp is in a remote location where access is by foot. This type of camp is often supported by a packer who transports the gear and supplies to the camp using horses and mules. Due to the logistical problems of transporting camp gear and supplies, a backcountry spike camp tends to be less developed and offers fewer comforts to the trail crew.

19.1.2.2. Frontcountry Spike Camp

A frontcountry spike camp is located at or near a trailhead and has vehicle access. This type of camp is typically used when it requires little time to commute to and from the project worksite. Due to vehicle access, this type of camp can be more developed than a backcountry camp. Additional facilities could include chemical toilets, generators, shower trailers, hot water heaters, large capacity potable water storage tanks, additional tables, and wall tents.

Most of the criteria used to locate a backcountry spike camp are applicable to a frontcountry camp. Sometimes a developed campground or day use area close to the trailhead can be used for the spike camp if it does not impact the public. Campgrounds and day use areas can make for an excellent spike camp with no additional impact on park resources.

19.2. Public Trail Camps

19.2.1. Site Selection

When selecting a location for a trail camp, the following criteria should be considered:

- Establish a relationship between the site, the trail system, and other overnight camping facilities. A trail camp should be placed along an extended trail at a maximum of one-day hiking distance from the trailhead or other camping facility.
- A trail camp should be located within 800 feet of the main hiking trail, but positioned to provide as much privacy and seclusion as possible.
- A trail camp should be located within 500 feet of a water source to provide reasonable access to water, but no closer than 150 feet to preserve water quality.

- Topography and exposure of the site to the elements are important considerations, particularly the slope, surface drainage characteristics, water table depth, solar orientation, prevailing wind direction, and severity of typical rain storms. Sites for trail camps are relatively flat (ideally less than 5% slope) and have good drainage or water escapement. Tent pads should have slopes of less than 3%, which may require minor grading.
- Soil should be evaluated for characteristics such as drainage, erosion, percolation (for human waste disposal), and resistance to compaction.
- Vegetation should be evaluated for resistance to trampling, overstory protection (shade), screening capabilities, and erosion control effectiveness.
- Water sources should be evaluated for potential use as drinking water and for recreational opportunities.
- Potential hazards from tree failures, landslides, flooding, animal encounters, insects, and noxious plants should be evaluated to assess visitor safety.
- Isolation of the site should be considered. A trail camp should be free from vehicle or logging noise and visual contact with highways and other developed areas. A sense of isolation is important in a trail camp.
- Evaluate the availability of on-site building materials such as stone, downed logs, and gravel. The ability to haul or pack in building materials to the site should also be considered.
- Evaluate accessibility for park personnel to patrol and maintain the site. Although remote locations are desirable, basic housekeeping, maintenance, visitor safety, and resource protection activities must be performed on a routine basis. Contingency plans should be developed for emergency evacuation of ill or injured visitors.
- A facility for disposal of human waste must be considered, especially since trail camps are designed for overnight use. Soil conditions must be analyzed, if a leaching system is used for a pit toilet or a composting toilet. Frequency of camp use should also be considered when determining the waste disposal method. Other factors to be considered include privacy, odor control, and groundwater contamination.
- If trash receptacles are not provided, users must pack out their trash. This requirement needs to be in all the literature pertaining to the camp and signs must be posted at the trailhead and at the camp.

- When feasible, trail camps should be located to maximize views and sounds of desired landscape features such as lakes, streams, mountains, rock outcrops, meadows, and canyons.
- Consider the potential carrying capacity of the camp. How much use can the site receive before resource degradation occurs, the maintenance and operational cost becomes excessive, or the visitor experience is diminished?

19.2.2. Site Design

A trail camp's design, amenities, and administration will be dictated by the type and quantity of use. A large group requires a large facility and more amenities than a small group. Horseback riders will require facilities and amenities specific to the care and feeding of their animals. Boat-in campers will require mooring or dock facilities as well as access from the shore to the campsite. The type of use needs to be identified prior to site selection, design, and administration.

The type of amenities provided may include a fire ring or grill that is protected from prevailing winds; a food box or hanging pole to keep food away from animals; and picnic tables, toilets, and/or shelters. Design should not exceed the minimum necessary to meet user needs so as to maintain the minimalistic experience users expect from a trail camp.

19.2.3. Accessibility

All new public trail camps need to address access for persons with disabilities pursuant to the Department's Accessibility Guidelines and the Architectural Barriers Act Accessibility Guidelines for Outdoor Developed Areas. These guidelines require that accessibility of trail camps be addressed regardless of whether or not the trail leading to them is accessible.

19.2.4. Signage

Campsites and amenities should be clearly marked to direct users and avoid the development of volunteer trails that result when users wander around a trail camp.

19.2.5. Latrines

A human waste facility should be located within a short distance of the trail camp. If a toilet is located too far from the campsite, it discourages use and promotes unsanitary conditions within the immediate vicinity. Toilets should be located downwind from campsites and positioned to provide privacy.

There are numerous designs for backcountry toilets; the most commonly used are the pit toilet and the self-composting toilet. Before selecting an outdoor toilet design, contact the local health department to determine if there are any requirements that

will affect the design selection and to confirm that the selected design options are consistent with local ordinances. Also consider frequency of use.

19.2.5.1. Pit Toilets

The most familiar toilet facility in backcountry is the pit toilet. A pit toilet is an unsealed hole in the earth, 3 to 6 feet deep, with a small privy placed on top. Several important criteria must be adhered to when installing this type of facility.

- A pit toilet should not be installed on a floodplain and should be at least 200 feet from waterways.
- A pit toilet should be located at least 50 feet from campsites or shelters.
- A pit toilet should be no deeper than 6 feet below the original grade. The bottom of the pit is at least 2 feet above the highest seasonal groundwater level, impervious layer, or bedrock.
- A pit toilet should be air-tight, except for the vent stack and waste entry hole.
- The area around the privy and pit should be banked to direct surface water away from the hole. The drip line of the privy roof should extend outside the mound surrounding the hole.
- The waste entry hole should have a self-closing lid and a ringed or semi-ringed toilet seat.
- A vent stack of at least 12 inches in diameter should be installed. This vent should extend into the seat box and reach a minimum of 2 feet above the highest point on the roof. The vent stack should have a rain cap to prevent precipitation from entering.
- The privy should have adequate ventilation and a self-closing door. It should also be screened and sealed against flies, rodents, and other vermin.

19.2.5.2. Self-Composting Toilets

A self-composting toilet is another human waste facility that has a backcountry application. Although it is larger and more expensive than a pit toilet, it has several advantages, such as less groundwater contamination, less odor, and a longer period of use before it needs to be removed or dug out. The disadvantages are that they operate only in temperate environments (average of 65 degrees Fahrenheit) and are so sensitive to temperature, humidity, and air movement that they often fail to work properly.

Two common designs are the “continuous composting toilet” and the “batch or bin composting toilet.” Continuously composting toilets depend on aerobic bacteria to break down waste, similar to that of outdoor composting. Waste is composted with carbon-rich sources like wood shavings, bark mulch, and leaves. As with any compost, the end product is a soil-like material similar to humus and is typically hauled away for use or deposit in an appropriate location. Continuous or single composting toilets contain only one chamber. As a self-contained composting toilet, all excrement and composting materials go into the top and are removed from the bottom in a continuous fashion. Double or batch composting

toilets consist of two or more containers. With this type of system, the composters are filled and allowed to age before additional excrement and other materials are added and therefore require regular attention and maintenance. Waste must be transferred from the toilet to the bin, periodically mixed, and organic compost material added on a regular basis

19.3. Public Trailside Shelters

19.3.1. Site Selection

Site selection considerations listed above for public trail camps should also be used for public trailside shelters. A trailside shelter is similar to a backcountry camp but the shelter provides campers with a durable structure that offers protection from the elements.

19.3.2. Structure and Site Design

Once a location has been selected, the design should be considered. The complexity of the design is determined by the availability of funding for construction and maintenance, anticipated vandalism, site location, and desired use. The size of the structure should be dictated by the anticipated number of users, the intended type of user experience, and the capacity of amenities such as water and toilets. Shelter size and associated amenities will also affect construction and maintenance costs and may dictate the type of user groups that will want to use the shelter. For example, a large shelter with more amenities may encourage unwanted destination or multi-night camping at a shelter intended for enroute (single night) use.

Regardless of what kind of design is selected, the shelter should not place undue pressure on or damage to natural or cultural resources and should match the anticipated volume and type of use.

Trailside shelters have a minimum of three vertical walls and a roof, and are positioned so that the open side faces away from prevailing storms and wind. This orientation enhances the structure's ability to provide a warm, dry shelter and enables smoke from the campfire to blow away from campers and their gear.

The surrounding vegetation and topography will influence design selection, along with available stone, wood, gravel, or soil that can be used in construction. The architectural design employed throughout the park or district may also be a factor in the design of a trailside structure. See Appendix L for examples of different trailside shelters.

Whenever possible, a foundation of native stone should be used to prevent earth to wood contact. If native stone is not available, imported stone or concrete may be an alternative. The building materials for a trailside shelter should be consistent with the local area. For example, redwood should be used on the north coast, cedar in

the Sierra, and stone in the desert. Pressure-treated materials should not be used in parts of the structure that can be contacted by the public.

Minimum amenities for a trailside shelter typically include a warming/cooking campfire pit or ring; pegs to hang packs or clothes; a table or elevated platform for eating and cooking; sleeping platforms or bunks; shelving; and a food storage facility that is secure from rodents, birds, and other wildlife who are often attracted to campsites. If the shelter is in bear country, a bear-proof storage locker or bear pole should be provided.

19.4. Equestrian Camps

19.4.1. Site Selection

An equestrian trail camp shares many of the site location and facility-planning criteria used for trail camps and trailside shelters. The difference between planning for an equestrian camp and other types of trail camps is accounting for the impact of stock, mainly horses and mules, on natural resources. Horses and mules are large animals that, if not staged and confined properly, can severely impact fragile soil, plants, and waterways.

To select a site for an equestrian camp, soil in the area must be carefully evaluated. The scuffing, scraping, and treading of hooves quickly erode thin loamy soil and can turn wet clay and silt into a quagmire. Firm, well-drained soil with protective ground cover is the most suitable for equestrian camps. The side slope in a stock holding area should not exceed 5% to minimize the mobilization of loose, unconsolidated soil during a rain event.

Vegetation within the equestrian camp must also be evaluated. Trail stock can trample or overgraze fragile plants if left unattended, and can also introduce competitive exotic plants through their feces. Cultural landscaping, including historic orchard trees, should also be protected. Areas with predominantly native plants (especially grasses) should not be used for equestrian camps. Vegetation that is resistant to trampling or grazing is preferable.

Bodies of water such as streams and lakes are also susceptible to damage by stock. Stock that is watering or grazing near water can trample riparian vegetation and erode the bank. Stock also contaminates potable water sources by urinating and defecating directly in the water or its immediate watershed. Stock feces also accelerate the eutrophication of lakes by adding nitrogen-rich organics to the water.

19.4.2. Hitching Rails

Hitching rails should be provided to restrain stock and reduce conflicts between them. (See Photo 19.1.) When not being used, stock are tied to the rails to prevent them from wandering out of the designated holding area. Sufficient hitching rails should be provided to accommodate the maximum number of stock allocated for the

camp. The rails should be located at least 150 feet from campsites and 300 feet from the nearest waterway. Short, well-spaced hitching rails (10 to 12 feet long) are preferred to long, tightly-spaced rails. (See Figure 19.1.)



Photo 19.1 - Hitching Rail

Construct hitching rails by placing posts into the ground and spanning them with a rail. (See Figure 19.2.) The posts and rails should have a minimum dimension of 6 x 6 inches and be made of construction heart redwood or cedar. Pressure treated lumber must not be used on hitching rails because horses often chew on the railings. The posts are set into the ground a minimum of 36 inches deep, and the rails have a maximum span of 10 feet from the center of each post. The rails are fastened with 60D galvanized nails and have a finished height of 54 inches.

19.4.3. Corrals

A corral to contain stock not in use can also be provided at an equestrian camp. A corral confines stock to a designated holding area, reducing impacts to the surrounding soil, vegetation, and waterways. A corral should be large enough to accommodate the maximum number of stock allowed in the camp and be located at least 200 feet from the nearest campsite and 400 feet from the nearest waterway. The distance from campsites and waterways should be greater than for a hitching post because of the increased use and quantities of animal waste associated with a corral.

A corral site must provide ample shade or shelter. Limbs from overhanging trees must have a minimum clearance of 10 feet, and all brush must be removed from within the corral. If a natural shelter is not available, a small lean-to should be constructed.

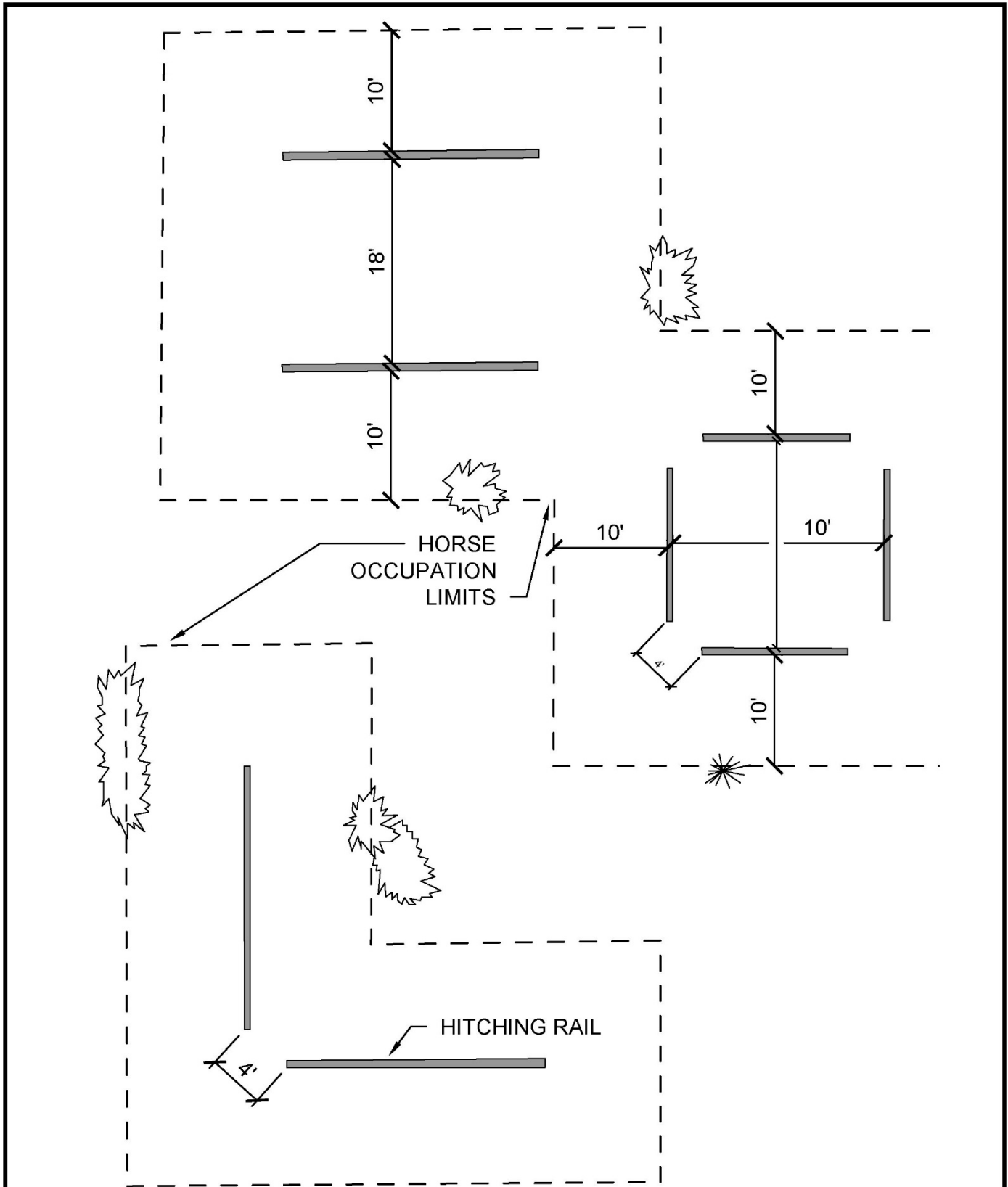

Figure 19.1 - Hitching Rail Placement



HITCHING RAIL PLACEMENT

CALIFORNIA STATE PARKS

NOT TO SCALE

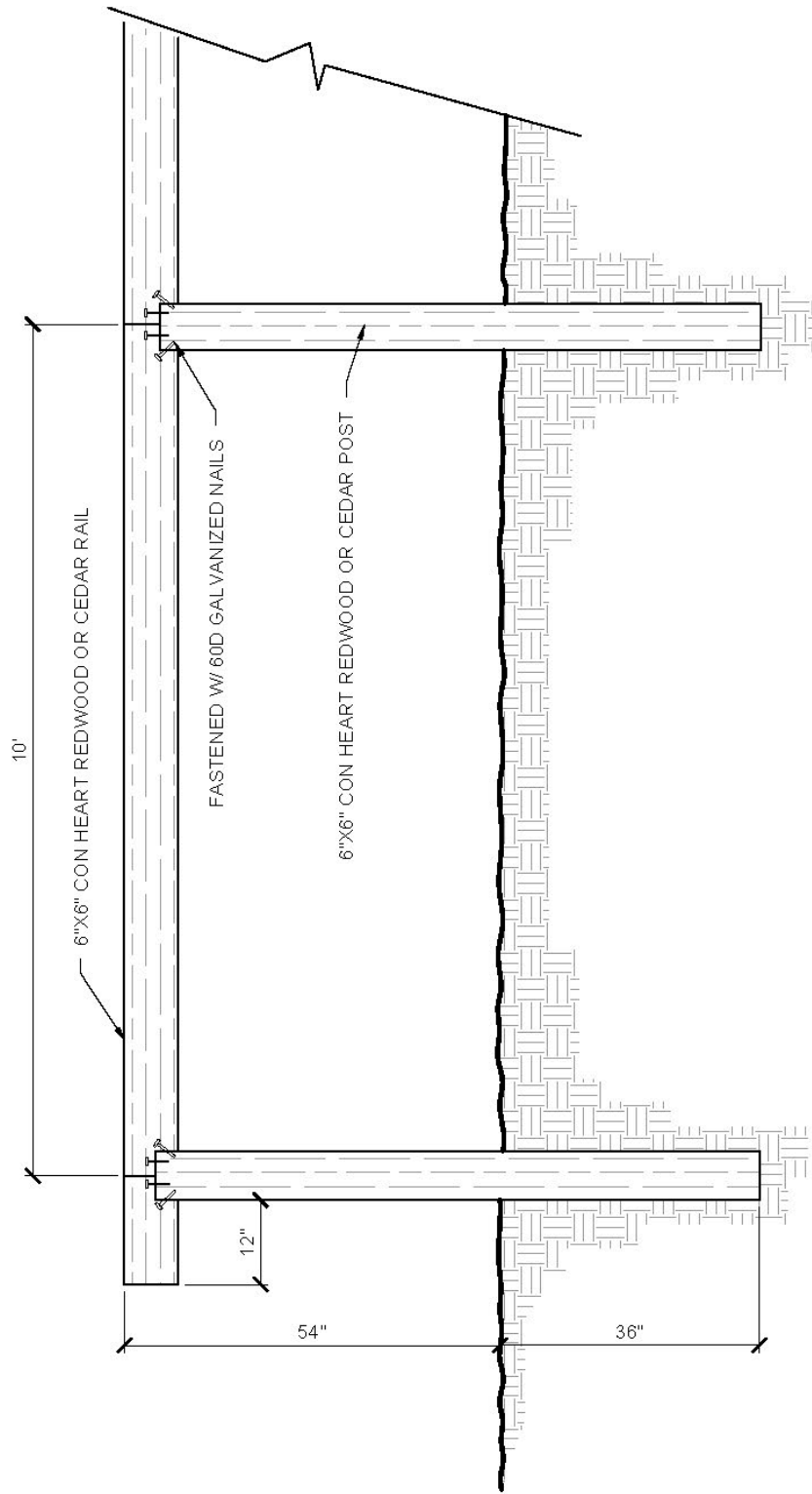

Figure 19.2 - Hitching Rail Construction



HITCHING RAIL CONSTRUCTION

CALIFORNIA STATE PARKS

NOT TO SCALE

A corral can be constructed with a variety of materials, such as wire, metal, or wood. The material selected should be compatible with the surrounding environment. For example, split rail or log fencing blends into a backcountry setting and provides a more rustic appearance. Wire and metal fencing is longer lasting and requires less maintenance, but is more visually obtrusive on the landscape.

The safety of livestock and their handlers is important. Sharp corners should be avoided and nail or bolt heads should be set flush with the rails. Rails are cut flush with the post and have no protruding ends, or are designed so that overlapping ends are on the outside of the corral.

Two wooden corral styles that provide a rustic appearance and are very serviceable include post and rail and the split rail corrals.

19.4.3.1. Post and Rail Corral

The post and rail corral uses single vertical posts and horizontal rails. (See Figure 19.3.) Posts of 6- x 6-inch construction heart redwood or cedar are set 36 inches into the ground and have a finished height of 5 feet. Rails of 2- x 6-inch construction heart redwood or cedar are attached to the posts with 3/8- x 5-inch galvanized lag screws, for a finished height of 54 inches. The gate is attached to a single post that is reinforced by another rail post and cross bracing. Steel hinge pins are used to hang the gate from the post. Hinges located at the top and bottom of the gate are attached to the pins with a hinge rod. Gates are secured with a sliding wood latch. This latch slides between two gate rails and into a vertical post when secured. The latch is placed high on the gate to allow riders to operate it while on horseback.

19.4.3.2. Split Rail Corral

The split rail corral also uses vertical posts and horizontal rails. (See Figure 19.4.) However, two posts of 6- x 6-inch split redwood or cedar are set 30 inches into the ground, placed with one in front of the other. They should have a finished height of 66 inches measured from the ground. A flat field stone approximately 6 inches high is placed on the ground between the two posts to eliminate earth to wood contact and provide an air gap for the railing. A railing of 4- x 6-inch split redwood or cedar is stacked between the two posts in an alternating manner. (See Figure 19.4.) The railings should overlap each other by approximately 12 inches. Due to the stacking layout, the finished height of the railings is between 54 and 60 inches. Once all the rails are stacked between the posts, the tops of the posts are tied together with 8-gauge galvanized wire to prevent the posts from spreading apart. The gate is identical to the one used for the post and rail design, except the gate boards and cross bracing are hewn to match the coarser split rail. (See Figure 19.5.)

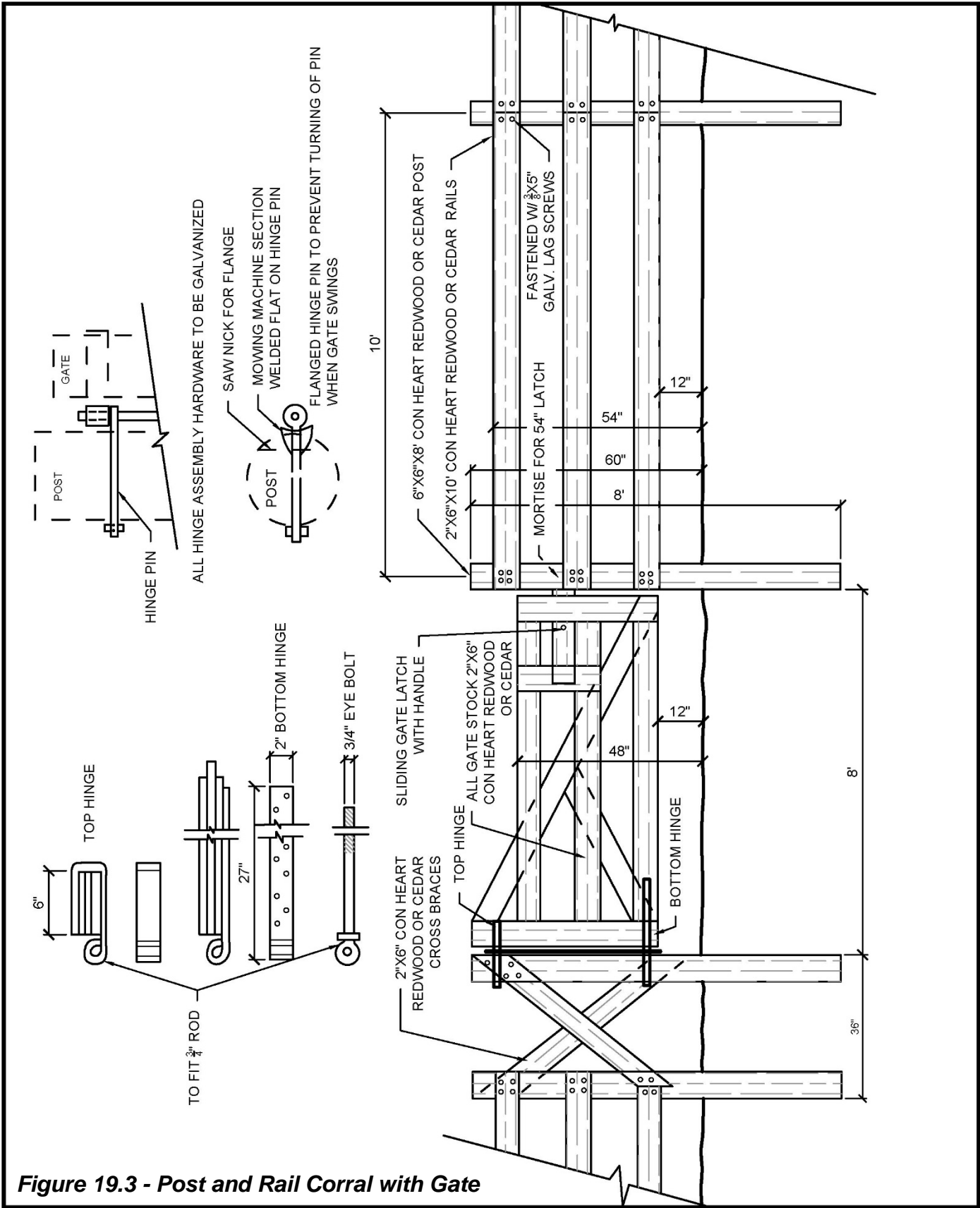

Figure 19.3 - Post and Rail Corral with Gate



POST AND RAIL CORRAL WITH GATE
CALIFORNIA STATE PARKS

NOT TO SCALE

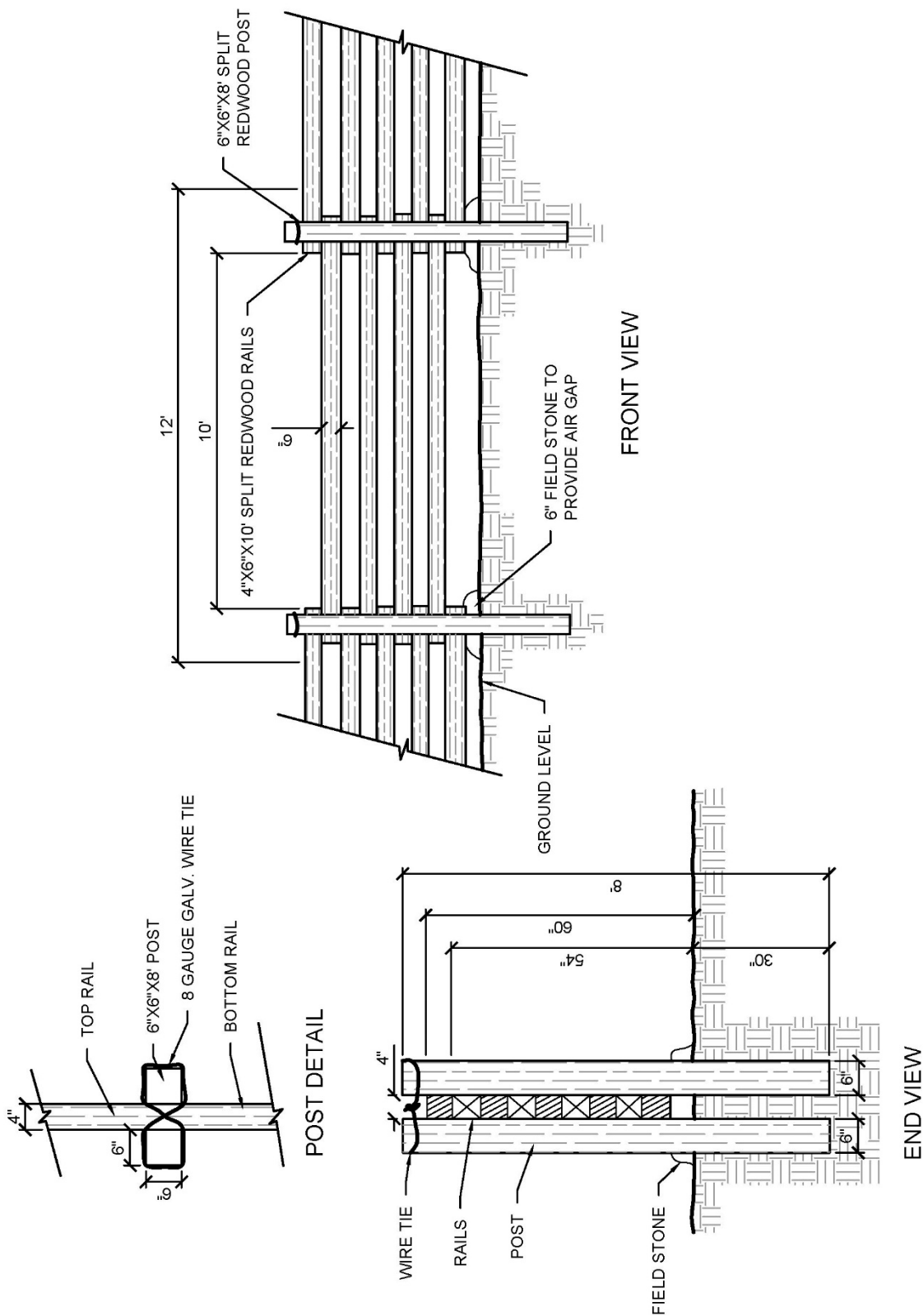

Figure 19.4 - Split Rail Corral Construction



SPLIT RAIL CORRAL CONSTRUCTION

CALIFORNIA STATE PARKS

NOT TO SCALE

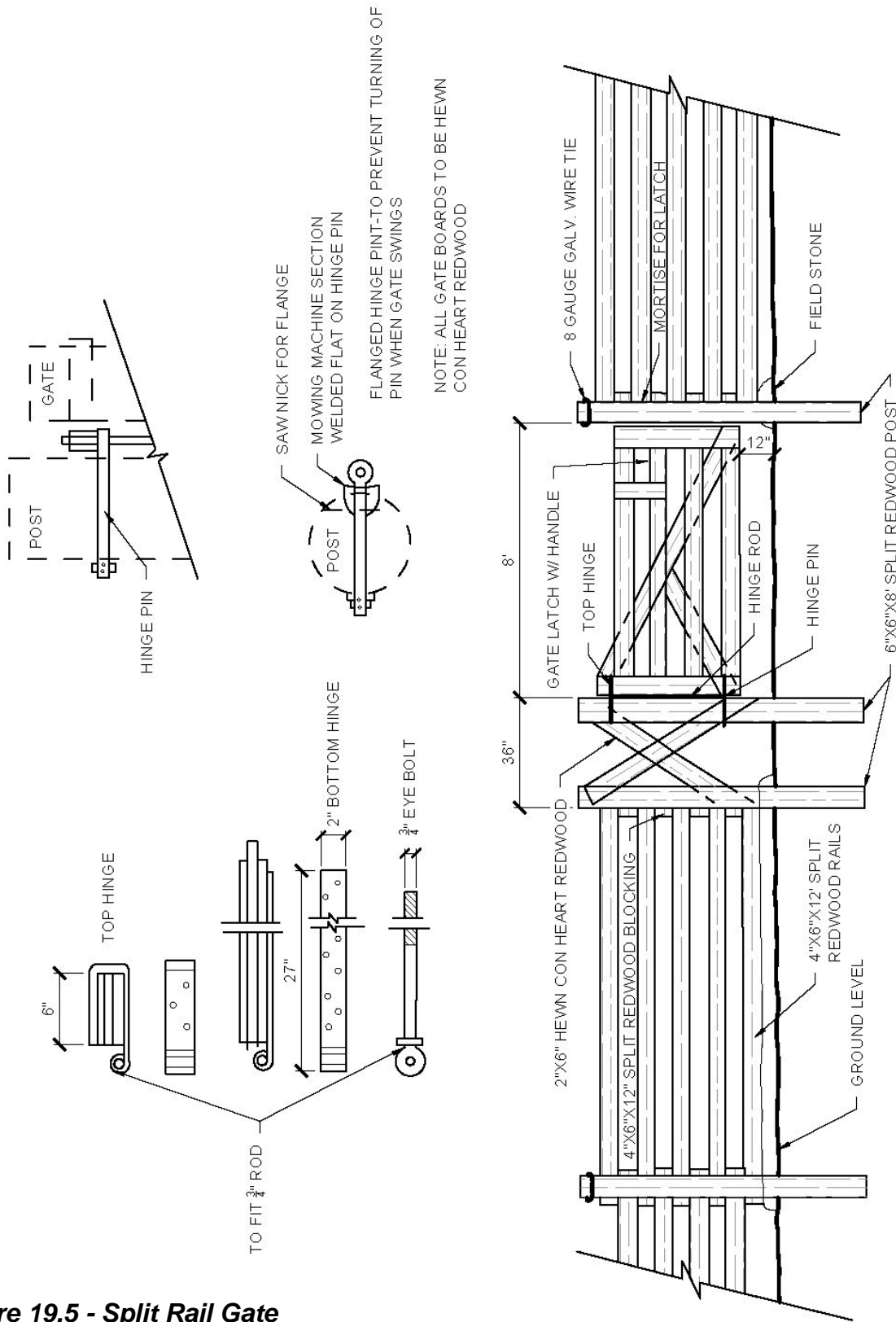

Figure 19.5 - Split Rail Gate



SPLIT RAIL GATE
CALIFORNIA STATE PARKS

NOT TO SCALE

19.4.4. Water Troughs

Since stock require water in large quantities and because stock must be kept away from natural bodies of water, watering troughs should be provided in the holding areas. Water should be piped in from a nearby spring or by installing a sand point pitcher pump.

19.4.5. Feed

Stock feed should be limited to grain carried in by the user, unless grazing or pasturing areas are identified and approved through the appropriate permitting process. Many government agencies require the use of certified weed-free feed to reduce the introduction and spread of exotic plants. When grazing is allowed, stock must be hobbled and tended. Picketing or tying animals to a tree is discouraged since it usually results in vegetation being denuded as well as scarring and breakage of the tree.

19.5. **Administrative Spike Camps**

When determining whether to use a spike camp, consider the cost of the crew's time spent commuting as well as the additional project time needed to accommodate the commute. Below is a comparison of the total labor cost of a three month project comparing a two hour commute to a project with no spike camp and a 15 minute commute to a project with a spike camp.

	2 hour commute one-way (No Spike Camp)	15 minute commute one-way (Spike Camp)
Daily commute per person	4 hours	0.5 hours
Daily commute per 10 person crew	40 hours	5 hours
Commute time for a 12-week (48-day) project	1,920 hours (19.2 days)	240 hours (2.4 days)
Total time (project time + commute time)	68 days (48 days + 19.2 days)	51 days (48 days + 2.4 days)
Total commute time	2,720 hours (68 days at 40 hours/day)	255 hours (51 days at 5 hours/day)
Total labor cost of commute at \$18/hour	\$48,960	\$4,590

In addition to labor costs, both forms of commute have other associated costs. For example, if a vehicle is required to bring the crew to the trailhead and return them back daily at \$100 a day, transportation for the sample project above can cost \$6,800 (68 days X \$100= \$6,800). A spike camp has expenses related to operations, particularly the provision of meals. An average spike camp costs approximate \$750 per week to operate (e.g., food, ice, camp stove fuel, lantern mantles, batteries, etc.). Thus, the cost of operating a spike camp for 51 days (12.5 weeks at four workdays per week) will be approximately \$9,375 (12.5 weeks x \$750 per week= \$9,375). If a backcountry cook is contracted at an average cost of \$4,750 per month, there will be approximately \$14,500 in cook costs (3 months x \$4750=\$14,500). The cost for packers to transport gear and food once a week to the camp could be an additional \$7,150 (\$125 a day per mule x 3 mules per week x 13 weeks = \$4,875; plus \$175 a day per wrangler x 1 wrangler per week x 13 weeks = \$2,275; \$4,875 + \$2,275 = \$7,150.) An additional \$2,600 in vehicle expenses is required to provide transportation to the crew on weekends for organized outings or going to a nearby town for personal shopping or recreation (13 weeks x 2 vehicle days a week = 26 vehicle days x \$100 = \$2,600). The total cost of commuting for both projects is as follows.

	2 hour commute one-way (No Spike Camp)	15 minute commute one-way (Spike Camp)
Total labor cost of commute	\$48,960	\$4,590
Vehicle	\$6,800	\$2,600
Spike Camp Operations	NA	\$9,375
Cook	NA	\$14,500
Packers	NA	\$7,150
Total Commute Cost	\$55,760	\$38,215

Thus, using a spike camp on a three month project is likely to cost nearly a third less as having a two hour one way or 4-hour round trip daily commute. These numbers will change based on crew size, work week length, project length, vehicle availability, type of cook, the amount of packing support required, and similar factors.

Establishing a spike camp may not only reduce the total project cost but it can shorten the project length by eliminating the extra commute time and improving crew productivity. A long project timeline may result in conflicts with wildlife restrictions, crew availability, visitor use, weather, etc. When a trail crew's workday is truncated by an excessive commute, it is more difficult to train and organize the crew. Many trail construction activities require time to set up and break down each day. That time is consistent regardless of how many hours the crew works. If it takes 45 minutes to set up and take down a project site and the crew only has 6 hours to work on the project,

the set up and break down represent 12.5% of the total workday. If the crew has 9.5 hours to work on the project, the set up and break down represents 7.9% of the workday. Over the course of several months of project work, this higher crew productivity will reduce the project timeline. In addition, when a crew has more time each day to work on a given task, skill development improves significantly and the crew experiences a greater sense of accomplishment.

19.5.1. Site Selection

Administrative spike camps should be established and operated in a manner that has minimal impact on the park's resources and facilities, efficiently implements the trail project, and provides a healthy and enjoyable environment for the trail crew. (See Photo 19.2.)



Photo 19.2 - Administrative Spike Camp

Living in the backcountry requires knowledge of low-impact camping techniques, potential environmental problems, park regulations, and first aid. Preferably, backcountry trail crews live in a camp located at an established site. A site is selected according to many factors, among them proximity to the trail and worksite. With a clear understanding of the environmental problems and the effects of human use on the backcountry, as well as anticipated future use, spike camps are chosen based on the following criteria.

As terrain permits, a 150-foot minimum distance between bodies of water and camp is required. A camp should be located at least 150 feet from the trail if possible and

never less than 100 feet. Human waste and gray water must be buried not less than 200 feet from a body of water, campsites, and the trail. (See Figure 19.6.)

New spike campsites are selected in conjunction with the trail supervisor and must be part of the project's environmental review and permitting process. Avoid constructing a new site unless there are problems with existing sites, such as the crew is too large to be accommodated by existing camps or existing camps are too far from the project.

The following factors are considered when locating a spike camp, some of which are discussed in more detail in the following sections:

- Proximity to project worksite
- Proximity to developed facilities and re-supply locations
- Stock/helicopter access
- Stock pasture/feed
- Access to water for stock and camp use
- Proximity to and visibility from the trail
- Local environment including the presence of bears or sensitive species
- Ability to have a campfire and availability of firewood
- Fire danger
- Sun/shade
- Dry site for cook tent or fly
- Human waste control and disposal
- Proper food storage for bear and corvid control
- Evacuation options

19.5.2. Site Design

The size of the crew and the length of time it will occupy the site will determine the size of the camp. Set-up a camp that is sufficient to meet the cooking and living needs of the crew. An elaborate camp takes more time to set-up and break down, and has greater potential for impacting the environment. Spike camps are intended to be a spartan temporary home for trail crews. A simple camp is the best choice.

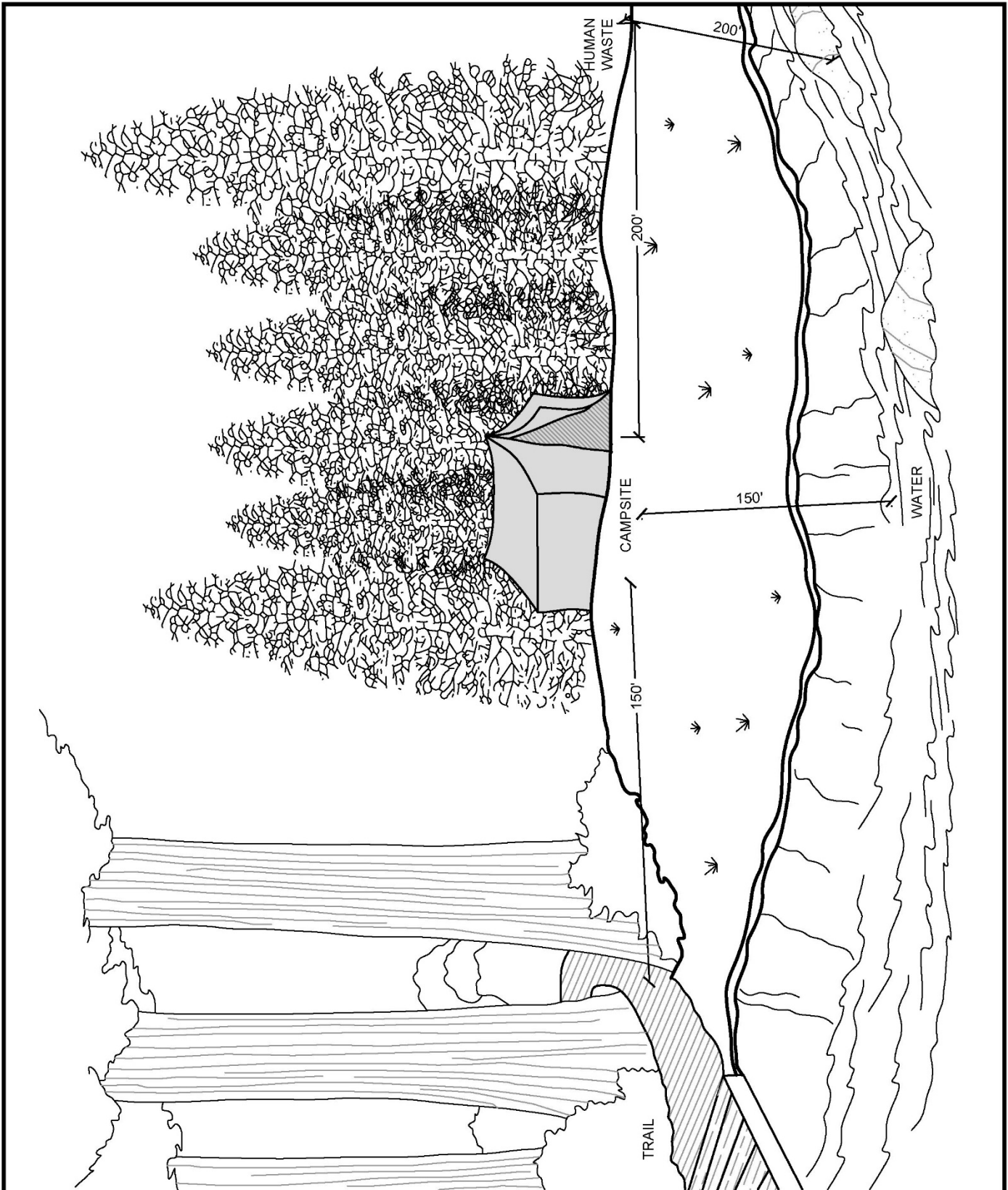

Figure 19.6 - Spike Camp Location



SPIKE CAMP LOCATION
CALIFORNIA STATE PARKS

NOT TO SCALE

Within the project's environmental review and permits, camp set-up depends on the location and the preferences of the crew. Sleeping tents are normally the lightweight backpack variety, fast to set up and take down. They are pitched outside of the camp's common area (e.g., cooking, dining, campfire, dish washing, and relaxation areas). Kitchen and dining areas should be covered with a large, heavy-duty rain fly stretched across a long skinny pole or tight rope. Cooking is usually done over a campfire with Dutch ovens or over white gas or propane camp stoves. Wall tents are often set up to provide shelter for the kitchen and the crew's community tent (a warm, dry location to relax, read, and play cards or board games during time off). The community wall tent can also be used as a dining area. When cold weather is anticipated, the community wall tent can be outfitted with a light weight wood stove to warm crew members in the mornings and evenings. A clothes line can also be set up inside the tent to dry wet clothes and gear during inclement weather. Lighting can be provided by white gas or propane lanterns.

19.5.3. Water

If municipal or well water is unavailable then potable water may need to be made by filtering water from a nearby stream or lake. In-line or large volume base camp bag filters can be used to purify water by eliminating harmful bacteria and cysts. Any water system that extracts water from a stream or lake must be identified in the project's environmental documents and permits.

Where permissible, a campfire can be used to sterilize water for washing via a jungle can (i.e., a 35 gallon can on a metal stand over the fire). (See Photo 19.3.) Boiled water is used for washing hands and faces, filling solar showers, and washing dishes.



Photo 19.3 - Fire Pit with Jungle Can

19.5.4. Kitchen

Discard used dishwater and other grey water into shallow sumps on the edge of camp, always more than 200 feet from water. (See Photo 19.4.) Dig a pit 12 to 18 inches deep and filled partially with large crushed rock, so the water will not be standing in the bottom of the pit for long periods. Place a wire screen over the pit to collect any silverware or food scraps that may be inadvertently thrown out with the dishwater. Use a similar sump for laundry water.



Photo 19.4 - Grey Water Sump

19.5.5. Showers

Providing a shower facility at a spike camp is important for proper sanitation and good crew morale. Showering helps reduce reactions to noxious plants, such as poison oak, poison ivy, or cow's parsnip. After a hard day of sweating and toiling in dust or mud, a hot shower greatly improves crew morale. It also makes being around fellow crew members a lot more pleasant.

Showers should be located a minimum of 200 feet from the nearest water, campsite, or trail. Locate showers on porous soil or over a shallow sump similar to the grey water sump. A wooden pallet with open slats can be laid out to stand on while showering to keep feet clean. A rope or some other device can be used to hang a solar shower over the wooden pallet. A privacy tarp is hung around the shower. Solar shower bags are set out in the sun each day to heat the bath water. If solar heating is insufficient, hot water from jungle cans can be used.

19.5.6. Latrine

If plumbed, vault, chemical, or pits toilets are unavailable or impractical, then a latrine (i.e., a large pit dug in the ground) may be required to dispose of human waste. Dig the latrine 200 feet or more from campsites, water sources, and trails.

The pit should be at least 3 feet deep and large enough to accommodate the number of crew members for the length of their stay, so that the waste is buried at least 12 inches under the surface when the camp is closed. A tarp should be hung to screen off the latrine and provide privacy. A toilet seat is installed for the comfort of the crew. Two parallel logs or a forked tree branch can be substituted for a toilet seat. Spread chlorinated lime and ashes from the fire in the latrine daily to control odors and insect activity.

19.6. Spike Camp Operations

It is important to remember that a spike camp is a community where people set up temporary residence. These camps may be occupied for several months at a time and support five to 15 or more people. As in all communities, there need to be simple guidelines that maintain order and efficiency and eliminate conflicts. The larger the trail crew and the longer the operation the more important these guidelines are. Trail crew leaders (if an in-house crew) or project leaders and crew supervisors (if an outside agency crew) should provide to crew and review with them the established guidelines on a routine basis.

19.6.1. Bears

Take precautions to protect food, gear, tack, and stock feed from bears. Bears are persistent and bear-proof storage facilities and negative reinforcement methods will not prevent some bears from entering the spike camp and attempting to break into any facility containing food or the smell of food. The best practice is to camp in an area without bears whenever possible. Refer to *Appendix M, Bear Management Plan*. Deterrent methods to consider are:

- Bear pole/cable (permanent or temporary)
- Bear boxes
- Electric fencing
- 24-hour camp watch and intimidation
- Bear-proof pack boxes or canisters

19.6.2. Garbage

Garbage should be a major concern of the trail crew. Whether it is trailside litter, burned trash from campfire pits, or garbage from spike camps, it is essential to pack out all trash. Never bury anything in the backcountry, except for cleaned campfire ashes and human waste. Buried garbage will not stay buried for long, because animals will dig it up and spread it around. Clean the backcountry whenever and wherever it is needed to give the public a positive impression of park management and protect resources.

19.6.3. Meals

Perhaps the most important element of operating a spike camp is ensuring the crew is provided with plenty of good, healthy food. Trail crews work extremely hard for up

to ten hours a day depending on their work schedule. They burn a lot of calories each day and require plenty of nutritious food. There is nothing more uplifting to a trail crew after a day of hard work than to return to camp and see and smell a well-prepared, hot meal. How that food is stored and prepared depends on the size of the crew and the length of the operation. To ensure that the crew is provided with a well-balanced diet and no one goes hungry, a menu must be prepared for each day and the corresponding food must be purchased and transported to the camp. The menu should take into account how long certain foods will last in the backcountry. For instance, fresh foods and foods that require refrigeration but can't be frozen should be first on the menu. If food can be stored frozen, it should be served a few days into the camp depending upon how well the food can be kept frozen. Meals using dried or canned foods should be planned for the end of the week.

Prior to any person being assigned or contracted to perform the duties of a backcountry cook, they must be tested for Hepatitis A, a viral liver infection. Hepatitis A is highly contagious. It is usually transmitted by the "fecal-oral route" when a person consumes food or water that has been contaminated by someone with the disease.

19.6.3.1. Small Crews

When a small crew of five people or less spike for a short duration, crew members can take turns cooking. Cooking duties may include breakfast and dinner or just dinner. The success of this system is dependent on the effort and cooking ability of each crew member and can be highly variable. If one of the crew members is a capable cook and willing to assume this role, then that person could be appointed the cook for the duration of the spike. This system usually ensures that the crew will be provided with a reasonably good meal each day. With both of these methods it is important to recognize that the person performing the cooking will not be working on the grade while they are preparing the meal so that the crew will be fed in a timely manner.

In some cases, the crew members are given a daily food allowance and are responsible for providing their own meals. The success of this method varies greatly depending on the maturity of the crew members. Some people see this method as an opportunity to save a little money and do not spend all their per diem on food, which can lead to poor nutrition. Others simply don't know how to cook healthy food. It is also more difficult to organize timely food preparation and meal schedules.

19.6.3.2. Large Crews

Organizing and managing food preparation for a large crew requires a skilled and experienced backcountry cook. This person is responsible for preparing the daily menu and associated shopping list, as well as shopping for and acquiring the food when in the frontcountry or coordinating the purchase and transportation of food via packers when in the backcountry. They are also responsible for setting

up and organizing food storage, preparation and cooking areas, preparing and cooking breakfast and dinner, and organizing and setting out daily lunch items. Additional duties include inspecting and cleaning food storage containers (e.g., ice chests), maintaining a clean and sanitary kitchen, washing cooking pots and pans used during the preparation of meals, maintaining the campfire if jungle cans are being used, and refueling and servicing lanterns and stoves.

Good backcountry cooks need to be skilled in planning nutritious meals and determining the quantity of food needed for the crew, and able to prepare a delicious and healthy meal with the barest of kitchen appliances and supplies. They must be able to cook with a camp stove, propane burner, propane oven, Dutch oven, open flame or coals, and/or a radiant/reflective heat oven.

Having a good backcountry cook greatly improves a spike camp operation and crew morale. Usually cooks with these skills are contracted for the duration of the spike camp operation. Because of high demand, contracting for these cooks must be done 6 to 8 months in advance of the trail project. See Appendix F, *Contracting*, for further information on contracting for a backcountry cook.

If the labor force for the trail project is a youth corps, such as the California Conservation Corps (CCC), a cook may be required as part of the contract. The CCC has training programs for cooks. One of these individuals may possess the requisite experience and skills to perform the cook duties in a spike camp. Individuals considered for this role must be thoroughly evaluated prior to being selected since finding someone capable of being a backcountry cook is not easy and finding the right person will make the difference between camp being enjoyable or just tolerable.

19.6.4. Sanitation Protocols

Spike camps must be maintained in a clean and sanitary condition for the health and safety of the occupants. Extra precaution must be taken to control the growth of bacteria and the spread of disease. These precautions must be taken seriously by every crew member due to the isolation of the living situation and the close proximity of the crew.

The camp is to be left neat and clean on a daily basis. Before going out on the trail each day, dishes are washed, garbage burned, food secured, and the camp area policed and left in an orderly manner. These activities are for the safety and sanitation of the camp, to present a positive image to the public, and to discourage marauding animals.

Each crew member must keep their personal space clean and sleeping bag aired out to prevent mice and other vermin from nesting in it. Wash clothes as needed. It is the responsibility of the crew leader (if an in-house crew) or crew supervisor (if an outside agency crew) to monitor the crew and set a good example.

19.6.5. Kitchen

The only people allowed in the kitchen area should be the cook, assigned helpers, and the crew leader (if an in-house crew) or project leader and crew supervisor (if an outside agency crew). (See Photo 19.5.) Other people entering the kitchen will add to the confusion, interfere with cooking activities, and potentially contaminate food.



Photo 19.5 - Kitchen

19.6.5.1. Hand Washing Station

Wash basins with hot water, soap, and clean towels must be located near the kitchen and dining areas so that crew members can wash upon entering camp and prior to handling food. There must be sufficient washing facilities to accommodate the number of people occupying the camp.

19.6.5.2. Lunch

Prior to making their lunch, crew members must thoroughly wash and dry their hands. Disposable plastic gloves may also be used to eliminate the potential for contamination. Utensils for serving food must be provided and used. Care should be taken to keep the handles of these utensils free of the food items being served or spread. People must take care to not spill food. Handling food with bare hands is prohibited. People should be aware of the amount of food available and not take so much that there is not enough left for the rest of the crew.

19.6.5.3. Breakfast and Dinner

Prior to serving or eating breakfast and dinner, everyone must thoroughly wash their hands. The food is set out on a table and the cook or their designated

assistant(s) serve the crew to help keep food distribution orderly and avoid over-consumption of food before all crew members are served. Note, a good cook will ensure there is plenty of good food for everyone and no one will go hungry.

19.6.5.4. Dish Washing Station

The entire crew, including the trail crew leader (if an in-house crew) or project leader and crew supervisor (if an outside agency crew) and guests, are responsible for washing dishes. This task is a community effort and by everyone being involved it is accomplished quickly and effectively. With everyone participating, the sense of community is reinforced and the crew's bonds are strengthened. (See Photo 19.6.)

The dishwashing process involves several stages to ensure sanitation and to minimize the possibility of rodents and bears being attracted to the leftover food. After each crew member finishes with their meal, the leftover food is scraped into a garbage container. It is preferred that the plate be wiped clean with a paper towel or napkin to keep food out of the dishwashing water and to minimize the amount of food scraps that will be poured into the sump with the grey water.

The dishwashing process involves four stations after the food is wiped off. At the first station, the dishes are washed in warm soapy water. The amount of soap used should be small because all soap on the dishes must be rinsed off and the less soap used, the easier it is to rinse. Soap left behind on the dishes can sicken the crew. After the dishes are washed they are rinsed in a container of clean water at the second station. At the third station, the dishes are sanitized in a container of water with a small amount of bleach. Dishes should be left in this water for at least 10 seconds. At the fourth station, the dishes are rinsed in clean water to eliminate the chlorine residue. The dishes are then dried and put away.

19.6.6. Common Areas

Areas of the camp that are shared by everyone, such as the dining area, campfire, and community tent (for reading and relaxing), must be free of personal gear, such as packs, safety gear, or clothing. When the crew gathers in the morning or after work, a location adjacent to these areas must be designated for storing packs and other personal gear to keep the common areas free of tripping hazards and less congested.

19.6.7. Latrine

To ensure the privacy of the crew, a flag or some other signal is hung by the latrine to let people know when it is occupied. Once someone is finished with the latrine, it is their responsibility to take the occupied flag down. They should also ensure there is sufficient toilet paper and restock it as necessary. Each day a member of the crew must be assigned to clean the toilet area and (depending on the latrine type) dump ash from the fire into the latrine to help eliminate odors.



Photo 19.6 - Dish Washing Station

19.6.8. Showers

It is the responsibility of the crew leader (if an in-house crew) or crew supervisor (if an outside agency crew) to ensure that crew members regularly shower and maintain good personal grooming. To maintain the crew members' privacy, a flag or some other signal is hung by the shower to let people know it is occupied. Once someone finishes showering, it is their responsibility to take the occupied flag down and leave the shower ready for use by the next person, which includes refilling the solar shower as necessary and returning it to the appropriate location.

19.6.9. De-Mobilizing Camp

Break camp by dismantling structures such as tents, benches, and tables. Do not burn or destroy poles or other materials that are in good shape and can be re-used in the future. Stash them near camp for the next crew.

Leaving behind a meticulously clean camp is the responsibility of all workers and cannot be overlooked in the rush to break camp. Always leave a campsite cleaner than it was before the camp was established. Minimize the size and number of holes or pits in and around camp, and always refill them with native soil when breaking camp. Police the campsite for non-native material such as bits of plastic or foil. If using an established campsite, the entire camp, including the campfire ring, should be left clean as an example to the public of minimum impact camping.

The campfire ring must be picked through to remove all foreign material. Allow the fire to thoroughly cool before picking through it. Ash from the fire should be buried in the latrine or grey water pits. Only thoroughly burned material should be buried. There should be no organic material that will attract curious animals.

If a temporary spike camp was established, rehabilitate the site to natural conditions, obliterating signs of tent pads, fire rings, temporary structures, latrines, sumps, and areas where stock have been tied or picketed. Aerate the soil, transplant appropriate native plants, and scatter duff over exposed soil.

19.7. Crew Behavior

19.7.1. Quiet Hours

Trail crew workers are normally exhausted at the end of every workday. A good night's sleep is critical to their performance and morale. If a crew is to begin work at 7:00 am, they are usually up by 5:30 or 6:00 am to allow enough time to dress, pack personal gear, wash up, make lunch, eat breakfast, wash dishes, use the latrine, stretch, and gather tools before hiking to the project worksite. To get in 8 hours of sleep, they need to turn in by 9:30 or 10:00 pm. To facilitate good sleeping conditions, the camp needs to be quiet by 9:30 or 10:00 pm. Loud noises such as yelling and music should not be permitted after these hours so crew members can sleep without being disturbed. The crew leader (if an in-house crew) or crew supervisor (if an outside agency crew) is responsible for establishing and enforcing quiet hours.

19.7.2. Smoking

Smoking in the backcountry may be prohibited due to wildfire or other resource management concerns. Before allowing crew members to smoke on the grade (i.e., worksite) or in camp, check with appropriate staff to determine if smoking is allowed or appropriate.

If allowed, rules for smoking must be established and followed. These rules may include that smoking on the grade may only occur during breaks or lunch. Smoking in camp is allowed only in a designated smoking area. The designated smoking area must be in a location free of material that could be accidentally ignited. The smoking area must be downwind from the non-smoking crew members. Cigarette smokers must not litter used butts and matches. If smoking is allowed, the butt should be packed out by the smoker with other crew garbage. It is a good idea to bring a small container with a tightly fitting lid to store cigarette butts until they can be properly disposed of in the frontcountry.

19.7.3. Alcohol

The consumption of alcohol at a spike camp is a controversial topic. Youth corps such as the CCC typically prohibit their crews from consuming alcohol while on a

spike. Do not indulge in drinking alcohol when camped with or next to a youth corps. Drinking in front of these young people sets a bad example. It is not a matter of whether drinking alcohol is bad, it is a matter of respecting the youth corps policy and not setting yourself apart from the crew that is working for you.

Agency crews drinking at a spike camp can also be problematic. Trail work is difficult and exhausting. At the end of a hard day's work, many crew members would like to relax with a beer or a mixed drink. The problem comes when the consumption of alcohol begins to affect the behavior of the crew or their work performance. Once alcohol is permitted in a camp it is difficult to regulate. For this reason, some agencies prohibit crews from drinking alcohol in camp. If drinking is permitted, the trail crew leader or supervisor must ensure that the privilege is not abused and take corrective action immediately when an abuse occurs.